



Vehicle tracking.

The introduction of new legislation relating to the fitment of tracking systems on all new vehicles from 2009 in Brazil, will require significant design modification to vehicles and manufacturers. **Car theft** and **vehicle tracking** requirements request **reliably standalone systems** that can transmit data via **GSM-CDMA Modems** specially with main **car battery disconnected**.

Battery challenge.

The combination of GPS and GSM system and the need to have sensor data from various positions inside the car requires an independent and powerful battery that is able to reliably work in the **harsh automotive environment** over the **extended temperature range**. Battery must be robust and rechargeable to withstand car crash and be steadily available at any time to **backup sending sensitive of data to service centre**.

Technical solution

The V500HT cell out of the powerful85 family of Ni-MH button cells from VARTA Microbattery is specially designed for high discharge currents and extended temperature from -20 to +85°C.

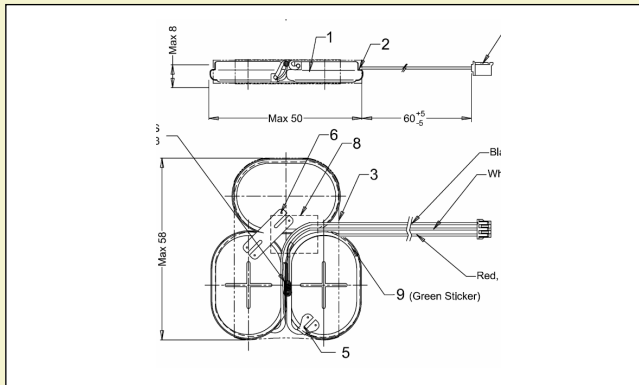

Characteristics	3/V500HT Battery
Voltage level	3.6V (other voltages possible)
Max peak discharge current	3A
Capacity	500mAh
Discharge Temperature range	-20°C to +85°C
Overcharge capability	0.03CA continuous
Weight	42g

Car Tracking Battery

VARTA Microbattery's Ni-MH HRT batteries (powerful85 family) offer rechargeable battery solutions with reliable power for supplying GPS and GSM Module in case of theft of car for tracking and locating of vehicle. Recommended configurations: 3/V500HT, 4/V500HT depending on temperature and power demand.

- wide temperature range from -20 to +85°C
- long lifetime – up to 10 years
- high reliability – by special sealing construction with new plastic materials
- high current capability with stacked electrodes
- design flexibility on voltage level from 1.2V to 12V
- design flexibility on battery shape side-by-side or stacked
- simple charging system continuous charging possible
- UL recognized cell
- ROHS compatible
- Halogen and Perchlorate free
- environmentally friendly Ni-MH technology

Vehicle Tracking

VARTA Microbattery GmbH
 Daimlerstraße 1
 73479 Ellwangen/Germany
 Tel +49 79 61 921-606

www.varta-microbattery.com